

Chroma Systems Solutions, Inc.

Tutorial on Safety Standard Compliance For Hipot Testing

19071, 19073 Hipot Testers

Keywords: Safety Issues, Electrical Shock, Fire, Hipot (Dielectric Withstand), Leakage Current, Arc Detection, Insulation Resistance, Ground Continuity, Ground Bond, Maximum Current Detect Mode, Minimum Current Detect Mode.

Tutorial on Safety Standard

Title:

Compliance For Hipot Testing

Product Family: **19071, 19073**

Tens of thousands of electrical, motor-driven, and/or transformer-type products are available to the consumer and to industry in categories such as business machines, consumer electronics, household appliances, power tools, communications, test equipment, and more. User safety with regard to these products has been a concern for the past one hundred years, or so, and the advances in safety measures progress with each passing year. Consumer advocates, industry spokespersons, the general public, and safety organizations such as Underwriters Laboratories (UL) continually monitor safety issues and recommend/implement changes to policy. In this article we will examine the most common international safety organizations' imperatives with regard to user safety. The organizations we site are UL, CSA (Canadian Safety Association), and VDE.

The hazards in question, with regard to the product categories mentioned, are electrical shock and fire. Electrical shock is caused when a current path between exposed parts of a device and the user is unintentionally created by some product fault. Compromised insulating materials and impeded grounding are two common culprits. Fire is caused when an electrical short or an overload condition occurs leading to sparking, overheating, and material combustion. Electrical shock and fire are minimized using the rigorous testing outlined in many safety standards. The electrical tests can be divided into four types:

Voltage: Hipot (Dielectric Withstand) Test

Current: Leakage Current, Arc Detection

Resistance: Insulation Resistance

Ground: Ground Continuity, Ground Bond

Hipot or Dielectric Withstand Tests

All safety standards recognize Hipot testing as absolutely imperative. A hipot tester (also known as dielectric or voltage withstand tester) imposes a voltage across a device higher than what normally would be seen by the device. With the Device Under Test (DUT) stressed in this manner, breakdowns or faults are analyzed. If a DUT can withstand potentials higher than normal it is expected that hazards at nominal potentials would be unlikely. The hipot tester also can perform leakage current tests. The

tester senses current (leakage) that flows through the DUT. The tester is programmed (or “adjusted” in case of analog equipment) to trip at a high and/or low current limit, and also in many cases, an arc detect limit (current detection modes explained in the next section). Two excerpts from UL Safety Standard 982 are provided below as examples of specified hipot and leakage current tests.

UL 982 Requirements

Hipot Test:

Page 62, section 28, UL 982 Safety Standard, “Motor-Operated Household Food Preparing Machines” Fourth Edition.

“An appliance shall be capable of withstanding for 1 minute without an indication of unacceptable performance the application of potential applied between live parts and accessible metal parts, between live parts of opposite polarity, and between any points of the primary and secondary circuits.

- a) 1000V for an appliance employing a motor rated at 1/2 horsepower or less.
- b) 1000V plus twice the rated voltage for an appliance employing a motor rated > ½ horsepower.
- c) 1000V, or 1000V plus the rated voltage, between the terminals of a capacitor used for electromagnetic interference reduction or arc suppression.”

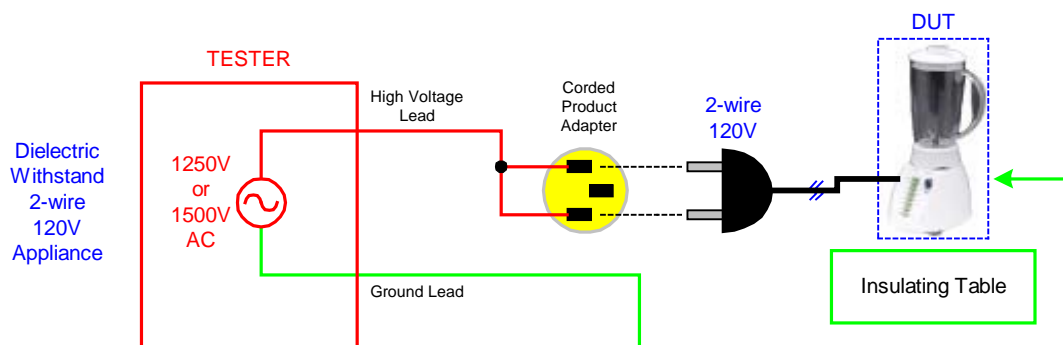

Figure 1: 2-Wire Hipot Test

Leakage Current Test:

Page 43, section 23 of UL 982 Safety Standard, “Motor-Operated Household Food Preparing Machines” Fourth Edition.

“The leakage current of a cord-connected appliance rated for a nominal 120 V supply when tested with 23.3 - 23.7 shall not be more than:

- a) 0.5mA for an ungrounded (2-wire) portable, stationary, or fixed appliance
- b) 0.5mA for an ungrounded (3-wire) portable appliances, and
- c) 0.75mA for a grounded (3-wire) stationary or fixed appliance employing a standard attachment plug rated 20A or less”

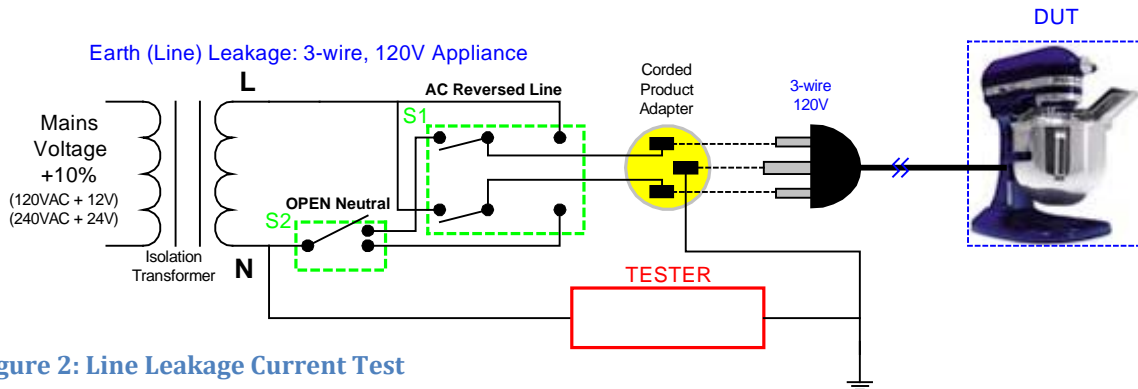

Figure 2: Line Leakage Current Test

Electrical Current Detection Modes

As detailed in the fore mentioned UL excerpts, voltage potentials and leakage current limits are absolutely specified and must be adhered to in order to achieve compliance. This is very typical of all safety standards since repeatability and, thus, the quality of each test must be assured. Lastly, safety standards direct that a DUT be tested for specific periods of time. Most hipot testers provide a means for programming test times and, in many cases, also ramp-to-test time which is a useful analytical test tool.

Maximum Current Detect Mode

As we've seen, a hipot tester imposes a voltage on a DUT, senses current, and at the same time compares the measured current with the user-programmed limits. In the case of the maximum current detection mode, the user programs an absolute high limit whereby the tester shuts down when the limit is reached alerting the user audibly, visually, and/or through a digital interface. Since safety standards typically provide the appropriate limits for compliance, it's a simple matter of transferring the specified limits of the standard in question to the programmable limit module of the tester.

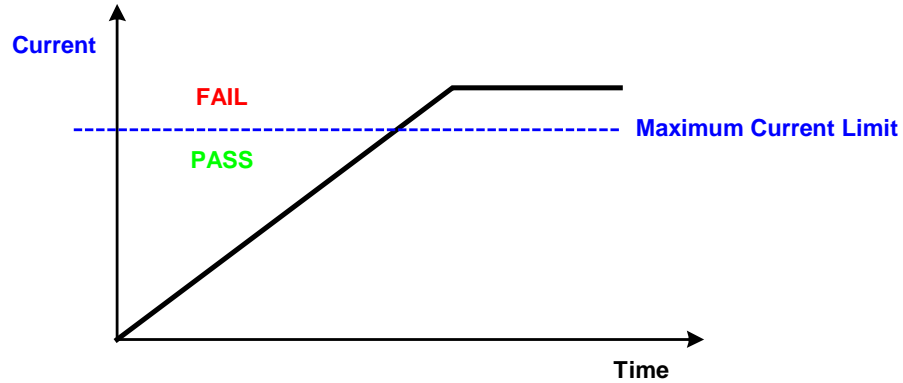

Figure 3: Maximum Current Detection

Minimum Current Detect Mode

Although not specified in safety standards, hipot testers equipped with Minimum Current Detection eliminate wasted time and effort waiting for incorrect measurements. Minimum Current Detection catches improperly connected and faulty cabling/fixtures before the tests start. It is given that a negligible amount of current safely flows when a DUT and associated cables and fixtures are in good working order and are correctly connected to a hipot tester. Furthermore, Hipot testers that detect minimum current recognize the difference between this safe nominal current and a problem condition. Therefore, the Hipot tester will alert the user if the cables or DUT are not correctly connected or if the cables or fixture are functionally unsound. Minimum current detection is programmed in the same manner as for the maximum current detect. The user specifies a minimum current limit that if not reached after testing has started, shuts down the tester and alerts the user to the condition. This saves time, increases productivity, and is invaluable to those who know (or will find out!) the hard way that bad parts can pass some tests with no actual connection to the DUT. Refer to Figure 4.

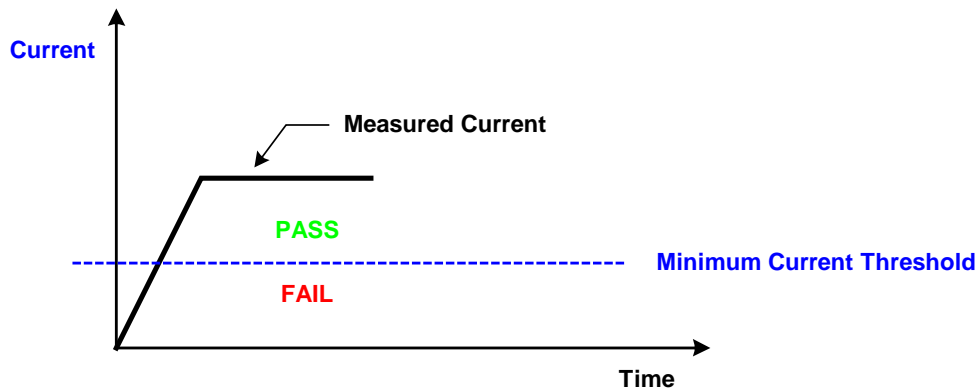

Figure 4: Minimum Current Detection

Arc Detection

Although Arc Detection is not directly addressed in safety standards to date (it is currently being considered for future inclusions) its use can further minimize hazard potential. A current arc is an electrical impulse that bridges a gap that separates two conductive areas. An example of current arc is the current that bridges the gap between the points of an automobile spark plug when an adequate potential is applied.

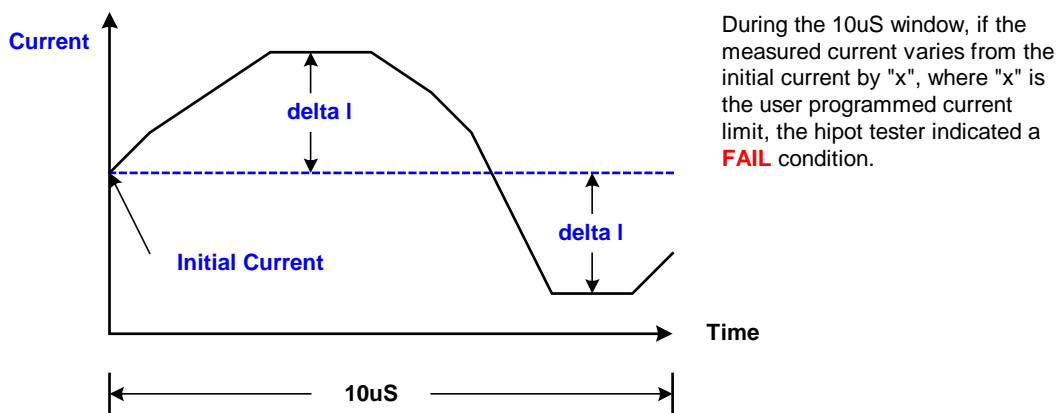

Figure 5: Arc Detection

Arc Detect can be used as a quick leakage current test thusly: Either of the two methods outline below can be employed in two distinct and separate ways. The first method uses a fixed window of time (typically in micro-seconds) and senses a current change during this window of time comparing the measured current with the programmed limit. The second method employs a fixed current limit and a variable programmable window of time. Arc Detect is a useful safety tool since it reacts in an “anticipatory” manner, meaning that the tester can determine at what level an electrical signal will be some point in the future based upon the trend or change in current over time. Obviously, this is a useful productivity tool as well as a tool to ensure safety. Refer to Figure 5.

Insulation Resistance

Insulation Resistance tests are commonly specified in safety standards and consist of high resistance measurements at relatively high potentials accompanied with a pass/fail detection function. Typically the resistance range for an insulation test is $1M\Omega$ to as high as the Tera (10^{12}) and Peta (10^{15}) and ohm regions. Voltage potentials vary from 50 to 1000V DC. Programmable limits provide simple pass/fail annunciation.

Ground Continuity

Ground Continuity tests are specified in safety standards and are, arguably, the most important safety test that can be implemented. This type of test ensures that accessible parts of a device, which are intentionally connected to a ground plane, do not witness any impedance to an electrical signal. If an electrical current potential is present on accessible parts of a product due to a product fault it is desired that this current be brought to ground and safely away from the user. Therefore, product is checked at final test to ensure that this is the case. Read the safety standard excerpt provided below to get an idea of what is required of the manufacturer, a description of the tests required for compliance follows the excerpts.

Page 30, section 19.2 of UL 982 Safety Standard, "Motor-Operated Household Food Preparing Machines" Fourth Edition.

"If a grounding means is provided on an appliance, whether required or not, all exposed dead metal parts and all dead metal parts which are exposed to contact during any servicing operation and which are likely to become energized shall be connected to the grounding means. Servicing, here mentioned, means user servicing, not repairs, made by a qualified service (person). The following are considered to constitute means for grounding:"

- a) In an appliance intended to be permanently connected by a metal-enclosed wiring system
- b) In an appliance intended to be permanently connected by a non-metal-enclosed wiring system.
- c) In a cord-connected appliance

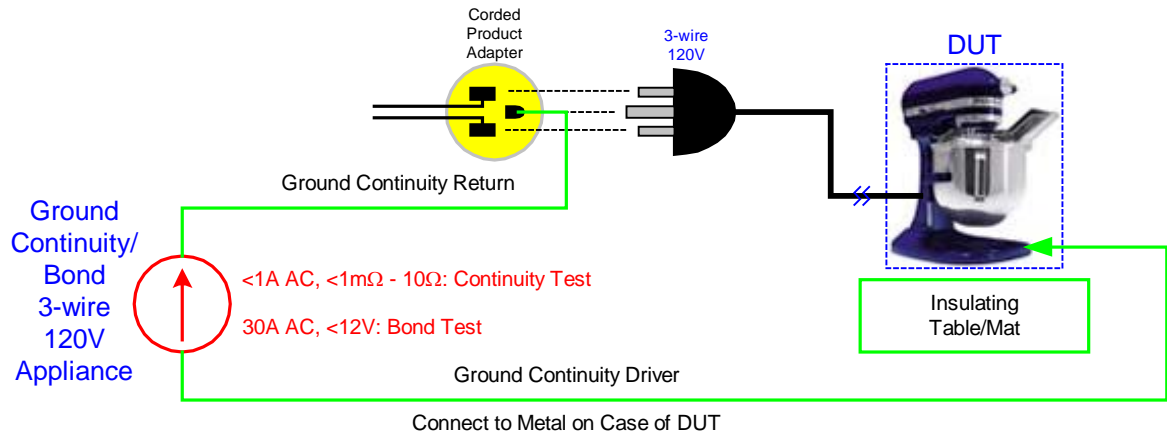

Figure 6. Ground Continuity Test

Ground Continuity & Ground Bond

The safety standard is straightforward in its intent but the manufacturer must take it a step further by insuring that, although a ground path exists, no inhibiting factors, which would impede an electrical circuit on its way to ground, exist. This is where the Ground Continuity test comes in. The basic test is a milliohm ($m\Omega$) test but since high current capability is required to simulate real-world condition, a simple milli-ohmmeter cannot perform this test. The electrical safety tester is set up to impose and direct an electrical current from the exposed metal part to the ground plane. While the tester is providing the test current, it simultaneously monitors resistance between the exposed part and the ground plane.

The current range typically used for continuity tests is 1 to 30A AC and the resistance range, 1 $m\Omega$ to 10 Ω . The difference between ground continuity and ground bond is the current used. A **bond** test verifies the existence and strength of the ground connection with a current equal to 20-30A. A **continuity** test verifies the existence of the ground connection by measuring the resistance with a current typically equal to 1A. A resistance present in the path of the test signal indicates a problem and should be corrected before product is shipped to the end user. Figure 7 illustrates the connection of the DUT for a Ground Continuity test followed by a Hipot test.

Fig. 7 Connection to DUT for Ground Continuity & Hipot Tests *

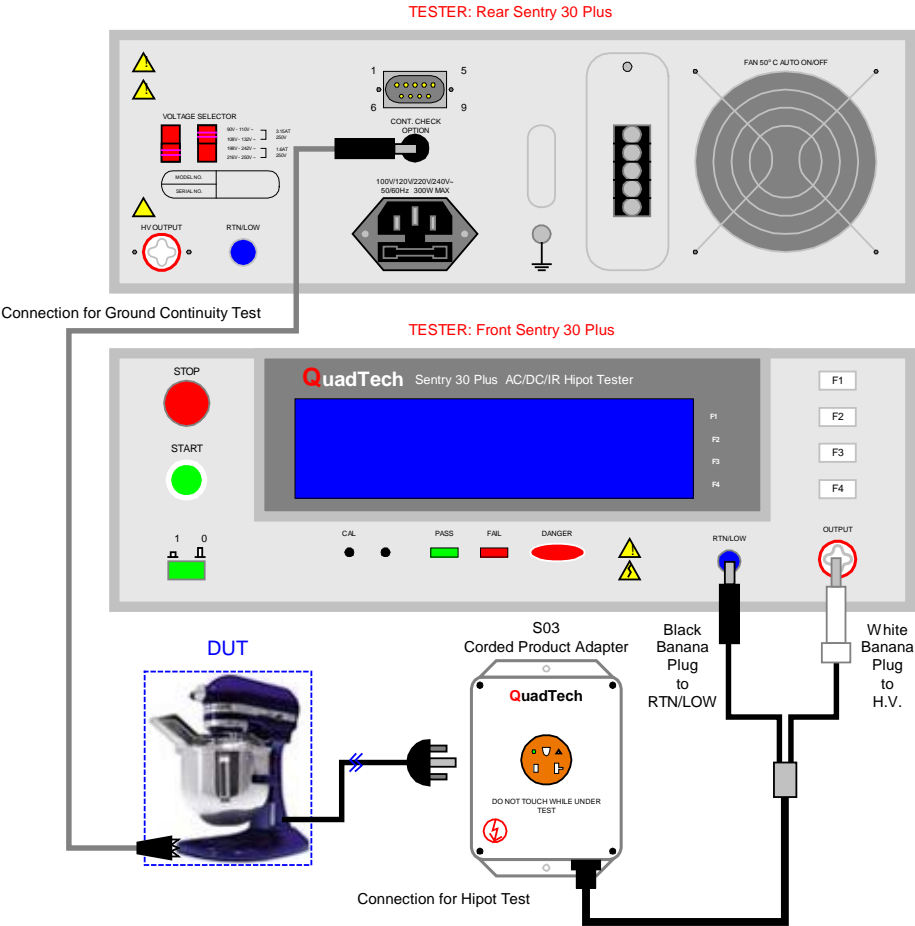

* Picture Shows Quadtech Sentry 30 Plus model which is equivalent to Chroma model 19073

Digital Hipots: Sequence Testing & More

Safety standards sometimes call for electrical safety tests to be run in sequence. For example, an insulation resistance test, then a hipot test followed by another insulation resistance test. The first IR test provides a nominal resistance value for a material under test and the hipot test imposes stress on this material. The final IR test in this example is performed to determine the affect, if any, the hipot test has on the insulation resistance. If the first IR result matches the second IR result, the integrity of the insulation has not been compromised. If however, the IR of the second test is much lower than the first, the hipot test compromised the insulation. If the material withstands the hipot test with no affect on its insulation resistance, the material can be relied upon for consumer use without worry.

Latent product failures are somewhat common but, fortunately, do offer some evidence as to their existence. Unless the right test equipment and methods are available however, detection can be very

difficult. Latent problems often go undetected and arise only after the installation at the customer site. It's easy to see why a manufacturer would want a device that offers sequence testing to do all that is possible in detecting these failures before shipping to the customer. Latent defects in a motor, for example, which will not likely result in an actual breakdown until the customer receives it, are most likely to be caught via the test sequence methods. First the Hipot test is performed, which is the best indicator of future motor failure, then an IR test is performed, which is the most common way to determine existing defects (including those that can be caused by the Hipot test itself). Digital hipot testers provide sequence testing and test parameter storage. This provides not only the ability to program and run a sequence of tests, but also the ability to store these tests in groups for later recall.

About the Underwriters Laboratories (UL) Safety Organization

By their own definition, Underwriters Laboratories, Inc., founded in 1894, examines and tests devices, systems, and materials to determine their relation to hazards to life and property. They define and publish standards and specifications affecting such hazards.

Underwriter's Laboratories, Inc.

333 Pfingsten Road

Northbrook, Illinois 60062-2096

(847) 272-8800, <http://www.ul.com>